

Bus description

PSD4xx positioning system – EtherCAT

Ether**CAT**<sup>®</sup> 



halstrup-walcher GmbH  
Stegener Straße 10  
79199 Kirchzarten  
Germany

Tel. +49 7661 39 63-0  
[info@halstrup-walcher.com](mailto:info@halstrup-walcher.com)  
[www.halstrup-walcher.com](http://www.halstrup-walcher.com)

© 2025

The manufacturer owns the copyright to this instruction manual. It contains technical data, instructions and drawings detailing the device's features and how to use them. It must not be copied either wholly or in part or made available to third parties.

The instruction manual is part of the product. Please read this manual carefully, follow our instructions, and pay special attention to the safety information provided. This instruction manual should be available at all times. Please contact the manufacturer if you do not understand any part of the instructions.

The manufacturer reserves the right to continue developing this device model without documenting such development in each individual case. The manufacturer will be happy to determine whether this manual is up-to-date.

## Table of Contents

<b>1</b>	<b>General</b> .....	<b>4</b>
1.1	Explanation of symbols.....	4
<b>2</b>	<b>Start-up</b> .....	<b>5</b>
2.1	Setting the “Explicit Device ID” and the “Configured Station Alias” .....	7
2.2	Switching on the device.....	7
2.3	Generating the delivery state (without the control unit) .....	7
<b>3</b>	<b>Description of EtherCAT</b> .....	<b>8</b>
3.1	EtherCAT interface with CoE protocol (CANopen over EtherCAT) .....	8
3.2	Status LEDs.....	8
3.3	Table of entries implemented from object dictionary .....	9
3.4	Table of device-dependent min., max. and default values.....	20
3.5	Process data format .....	23
3.5.1	Output module (from the perspective of the IO controller).....	23
3.5.2	Input module (from the perspective of the IO controller).....	23
3.6	Detailed description of status bits .....	24
3.7	Detailed description of control bits.....	28
<b>4</b>	<b>Functions</b> .....	<b>29</b>
4.1	Positioning.....	29
4.2	Types of positioning.....	30
4.2.1	Positioning run <i>with</i> reference loop .....	30
4.2.2	Positioning run <i>without</i> reference loop.....	31
4.2.3	Manual run.....	31
4.3	Maximum start-up and operating torque.....	32
4.4	How to respond if the drive encounters an obstruction .....	33
4.5	How to respond if drive is turned manually (adjustment function) .....	34
4.6	Calculate the absolute physical position.....	35
4.7	Set the spindle pitch.....	38
4.8	Abort the run when the master fails.....	38
4.9	Reference runs.....	39
4.10	Run drive in reverse.....	40
<b>5</b>	<b>Technical data</b> .....	<b>41</b>
<b>6</b>	<b>Notes</b> .....	<b>41</b>

# 1 General

This bus description is to be used for the commissioning and integration of the drive into a field bus system.

Technical data for the electrical connections of your drive can be found in the electrical connector and pin assignment description on the website:



[www.halstrup-walcher.de/technicaldocu](http://www.halstrup-walcher.de/technicaldocu)

Please search for "PSD" and select your type, click on "Instruction manuals" and download the "connector and pin assignment" offered for your bus system.

## 1.1 Explanation of symbols

The device has been designed and tested to ensure its safety. However, it may still be dangerous if used inappropriately. Precautions must be taken to prevent the device being used incorrectly by mistake.

The following warnings are used in this instruction manual:

 <b>DANGER!</b>	<b>DANGER!</b> Indicates a situation of imminent danger, which will lead to a fatality or serious injuries if not prevented.
 <b>WARNING!</b>	<b>WARNING!</b> Indicates a potentially dangerous situation, which may lead to a fatality or serious injuries if not prevented.
 <b>CAUTION!</b>	<b>CAUTION!</b> Indicates a potentially dangerous situation, which may lead to minor/slight injuries if not prevented.
<b>NOTICE</b>	<b>NOTICE</b> Indicates a potentially harmful situation, which may lead to material damage if not prevented.

## 2 Start-up



### WARNING!

Risk of injury if used inappropriately.  
The device must be installed by trained technical personnel.



### WARNING!

Risk of burns due to hot drive.  
The drive can become very hot during operation.  
Allow the drive to cool before touching it.



### WARNING!

Risk of crushing due to rotary movement.  
Do not reach into the working area of the drive when it is still turning.  
The user/operator must ensure appropriate protective measures are taken.



### WARNING!

Incorrect assembly can lead to the destruction of the drive.



### WARNING!

Check that the supply lines are not pinched or crushed.  
Lay the supply lines according to the general and specific local assembly regulations.  
If the supply lines have not been delivered together with the device, please select suitable cables for the application.  
Do not operate the direct drive if the supply lines are noticeably damaged.



### WARNING!

Risk of injury. High contact voltages can occur in the case of malfunctions.  
This can be prevented by grounding.



**CAUTION!**

The drive must be protected against excessive heating.  
The user/operator must ensure appropriate protective measures are taken.



**CAUTION!**

Never apply force to the housing of the drive, e.g. for supporting weight.

## 2.1 Setting the “Explicit Device ID” and the “Configured Station Alias”

The device’s “Explicit Device ID” can be set using the two rotary switches (address switch value > 0). If the address is set to value 0, the “Explicit Device ID” can be set using SDO #2026. In this case, the value is only accepted into the ESC and SII after saving (see SDO #204F) and restarting.

Additionally a “Configured Station Alias” can be assigned via the bus of the EtherCAT master. This value can also be set using SDO #2026. In this case, the value is only accepted into the ESC and SII after saving (see SDO #204F) and restarting.

## 2.2 Switching on the device

After connecting the supply voltage, you can begin positioning or manual runs immediately.

You can find information about installing the drive as well as electrical connections and pin assignments at the following link: [www.halstrup-walcher.de/technicaldocu](http://www.halstrup-walcher.de/technicaldocu)

Please search for "PSD" and select your type, click on "Instruction manuals" and download the “connector and pin assignment” offered for your bus system.

## 2.3 Generating the delivery state (without the control unit)

The drive can be reset to the delivery state even if no control unit is present.

Generate the delivery state as follows:

- 1) Separate the device from the electrical power supply.
- 2) Set the address switches to 98.
- 3) Switch on the device (control unit and motor voltage).
- 4) The yellow LED now flashes for 10 seconds at 10 Hz. If, during this time period, the address is set to 99, the drive will reset all parameters to the delivery state, save this setting and bring the axle to the mid-position.
- 5) Set the address switch to 00 in order to complete the delivery state.
- 6) Switch the device off.

The 10-second period will be ended early if any communication is established.

### 3 Description of EtherCAT

#### 3.1 EtherCAT interface with CoE protocol (CANopen over EtherCAT)

The EtherCAT interface uses the CANopen over EtherCAT protocol in accordance with ETG1000.6 Section 5.6:

One transmit and one receive SDO per device
One asynchronous transmit and receive PDO, active by default

#### 3.2 Status LEDs

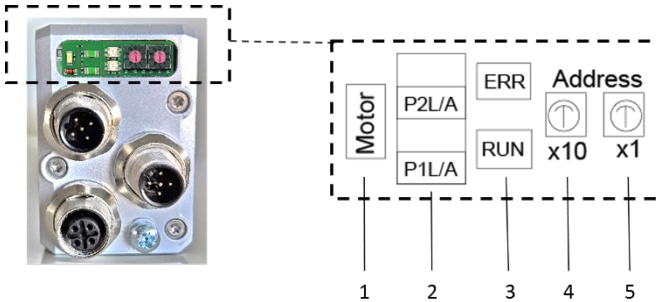

The following LEDs are located under the sealing plug:		
1	V_Motor	Yellow LED = Motor supply voltage
2	P1L/A	Green LED = Link/Activity
	P2L/A	Green LED = Link/Activity
3	Run	Green LED = Signals the ESM status
	Error	Red LED = Signals an error
4	X10	Address switch x10
5	X1	Address switch x1

#### Meaning of the LEDs:

Yellow LED motor supply voltage (V_Motor)	
Off	Motor voltage too low or too high
On	Motor voltage is OK
Flashing at 0.5 Hz	Motor voltage is OK and drive is in the delivery state



Each of the ports (P1/P2) has an associated green LED for the “Link” and “Activity” states.

<b>For each port (P1/P2), the following states are possible:</b>	
Off	No connection
On	Line connection is active, no data activity
Flashing at 10 Hz	Line connection is active, data transfer active

<b>The green “Run” LED signals the ESM status:</b>	
Off	INIT
Flashing at 2.5 Hz	PRE-OPERATIONAL
Flashing at 1 Hz	SAFE-OPERATIONAL
On	OPERATIONAL

<b>The red “Error” LED signals an error:</b>	
Off	No error
Single flashes at 1 Hz	Local error, application is changing ESM status
Double flashes at 1 Hz	Watchdog timeout
Flashing at 2.5 Hz	Configuration error

### 3.3 Table of entries implemented from object dictionary

Designation	Index no.	Function	Range of values	Back-up?	De-livery state	R/W
Device type	1000	Device type	0		0	R
Software description	100A	Identifies the software of the EtherCAT drives; returns the string “PSD4xxIE/ECAT” when read				R
Identity	1018	Sub index 0: No. of indices (= 4)	8 bit		4	R
		Sub 1: Vendor-ID (= 0x000002D8)	32 bit			R
		Sub : Product code	32 bit			R
		Sub 3: Revision number (= 0x00010000)	32 bit			R
		Sub 4: Serial number	32 bit			R

Designation	Index no.	Function	Range of values	Back-up?	De-livery state	R/W
Receive PDO 1 mapping	1600	Sub index 0: No. of indices (= 2) Sub 1: 0x20240010 Sub 2: 0x20010020	8 bit 32 bit 32 bit		2	R R R
Transmit PDO 1 mapping	1A00	Sub index 0: No. of indices (= 3) Sub 1: 0x20250010 Sub 2: 0x20300010 Sub 3: 0x20030020	8 bit 32 bit 32 bit 32 bit		3	R R R R
SM Comm Types	1C00	Sub index 0: No. of indices (= 4) Sub 1: SM0 (= 1) Sub 2: SM1 (= 2) Sub 3: SM2 (= 3) Sub 4: SM3 (= 4)	8 bit 8 bit 8 bit 8 bit		4	R R R R
SM0 PDO Assignment	1C10	Sub index 0: No. of indices (= 0)	8 bit		0	R
SM3 PDO Assignment	1C13	Sub index 0: No. of indices (= 1) Sub 1: 0x1A00 (1. TxPDO)	8 bit 16 bit		1	R
General purpose register	2000 0...10	10 general purpose registers Sub index 0: No. of indices (= 10) Sub 1...10: free register	8 bit 16 bit	Yes	10 0	R R/W
Target value	2001	Target position in 1/100 mm  (for a 4 mm spindle and default values of numerator, (SDO #2010) and denominator (SDO #2011)).  This value can only be written in the "pre-operational" state.	±31 bit	No	0	R/W

Designation	Index no.	Function	Range of values	Back-up?	De-livery state	R/W
Actual value	2003	Current actual position in 1/100 mm (for a 4mm spindle and default values of numerator, (SDO #2010) and denominator (SDO #2011)). Writing to this index number causes the current position to be “referenced” to the transferred value  Writing only possible when at a standstill.	±31 bit	No		R/W
Referencing value	2004	Correction factor for the target, actual and end limit values.  Writing only possible when at a standstill.	±31 bit	Yes	0	R/W
Drag error	2005	Reserved				
Positioning window	2006	Permissible difference between target and actual values for the “target position reached” bit in 1/100 mm (for a 4 mm spindle and default values of numerator and denominator)  The maximum setting value changes according to the same factor as the resolution.  Writing only possible when at a standstill.	1...100 16 bit  equals 0.0025 ... 0.25 rotations	Yes	2	R/W
Position scaling, numerator	2010	These values allow you to apply any resolution to the drive that you wish.  For a numerator factor of 400, the spindle pitch/resolution is stated in the denominator factor	1...10000 16 bit	Yes	400	R/W
Position scaling, denominator	2011	e.g.: Spindle pitch 1.5 mm with resolution 1/100 mm: numerator = 400, denominator = 150  Writing only possible when at a standstill.	1...10000 16 bit	Yes	400	R/W

Designation	Index no.	Function	Range of values	Back-up?	De-livery state	R/W
Target speed	2012	Maximum rpm to be used for positioning runs; value in rpm	See chap. 3.4 16 bit	Yes	See chap. 3.4	R/W
Target speed for manual run	2013	Maximum rpm to be used for manual runs; value in rpm	See chap. 3.4 16 bit	Yes	See chap. 3.4	R/W
Maximum torque	2014	Applies after the end of the start-up phase (during the start-up phase, the value of parameter #2018 applies); value in cNm	See chap. 3.4 16 bit	Yes	See chap. 3.4	R/W
Upper limit	2016	Maximum permitted target position  Permissible values: (upper mapping end - 1200 .. 1611600 * numerator/denominator)  For models with an auxiliary gearbox, the range of values is reduced in accordance with the gear ratio.  Writing only possible when at a standstill.	±31 bit	Yes	101200	R/W
Lower limit	2017	Min. permitted target position  Permissible values: (upper mapping end - 1200 .. 1611600 * denominator/numerator)  For models with an auxiliary gearbox, the range of values is reduced in accordance with the gear ratio.  Writing only possible when at a standstill.	±31 bit	Yes	1200	R/W
Maximum start-up torque	2018	Value in cNm	See chap. 3.4 16 bit	Yes	See chap. 3.4	R/W

Designation	Index no.	Function	Range of values	Back-up?	De-livery state	R/W
Time period for start-up torque	2019	Time period during which the max. start-up torque (SDO #2018) is applied; value in ms	10...1000 16 bit	Yes	200	R/W
Speed limit for aborting run	201A	Value in % of the target speed	30...90 16 bit	Yes	30	R/W
Time elapsed until speed falls below speed limit for aborting run	201B	Value in ms	50...500 16 bit	Yes	200	R/W
Acceleration	201C	Value in rpm per second	See chap. 3.4 16 bit	Yes	See chap. 3.4	R/W
Deceleration	201D	Value in rpm per second	See chap. 3.4 16 bit	Yes	See chap. 3.4	R/W
Length of loop	201F	Minimum number of increments, in which the drive runs to a target in a specified direction.  Value in increments (0 → no loop)  The sign determines the direction of the loop: (positive → reference loop to larger values; negative → reference loop to smaller values)	0.025...10 rotations or -0.025...-10 rotations or ± 31 bit	Yes	250	R/W
Acceleration 2	2020	Reserved				
Deceleration 2	2021	Reserved				

Designation	Index no.	Function	Range of values	Back-up?	De-livery state	R/W
Control word	2024	Bit 0: Manual run to larger values Bit 1: Manual run to smaller values Bit 2: Transfer target value Bit 3: Reserved Bit 4: Release: the axle will only run if bit is set. Bit 5: Reserved Bit 6: Run without a reference loop Bit 7: Reserved Bit 8: Reserved Bit 9: Reserved Bit 13: Toggle bit All other bits must be set to 0 This value can only be written in the "pre-operational" state.	16 bit	No	0	R

Designation	Index no.	Function	Range of values	Back-up?	De-livery state	R/W
Status word	2025	Bit 0: Target position reached Bit 1: Reserved Bit 2: Toggle bit Bit 3: Reserved Bit 4: Power supply to motor available Bit 5: Positioning run aborted Bit 6: Drive is running Bit 7: Max temp. exceeded Bit 8: Run in opposite direction to loop Bit 9: Error Bit 10: Positioning error (obstruction) Bit 11: Manual rotation Bit 12: Incorrect target value Bit 13: Power was unavailable to motor Bit 14: Positive range limit Bit 15: Negative range limit	0... FFFFh 16 bit			R
Address	2026	Explicit Device ID  Write: When writing, the value is only accepted into the ESC and SII after saving (see SDO #204F) and restarting.  This value will only be used if the address switches are set to value 0.	16 bit	Yes	0	R/W

Designation	Index no.	Function	Range of values	Back-up?	De-livery state	R/W
Upper mapping end	2028	Definition of the positioning range relative to the absolute value encoder Permissible values:  (actual position + 3 rotations) ... (actual position + 4,029 rotations)  Writing only possible when at a standstill.	±31 bit	Yes	102400	R/W
Maximum holding torque	202B	Holding torque at standstill in cNm (after the phase "max. holding torque at end of run")	See chap. 3.4  16 bit	Yes	See chap. 3.4	R/W
Direction of rotation	202C	0: Clockwise rotation to larger values (if looking at the output shaft)  1: Anti-clockwise rotation to larger values  Writing is only possible when at a standstill.	0 or 1 16 bit	Yes	0	R/W
Idle period	202E	Reserved				
Actual speed	2030	Value in rpm	±15 bit			R
Max. current during last run	2031	Maximum current occurring during the most recent run (the start-up phase, during which the start-up torque applies, see SDOs #2018/2019, and braking phase are not taken into account);  value in mA	16 bit			R
Actual current	2033	Actual current, in mA	16 bit			R
U control	203A	Current supply voltage to control unit, in 0.1 V	16 bit			R
U motor	203B	Current supply voltage to motor, in 0.1 V	16 bit			R



Designation	Index no.	Function	Range of values	Back-up?	De-livery state	R/W
UMot limit	203C	Voltage limit for bit 4 ("Power supply to motor available"); in 0.1 V  A positioning run or manual run can only begin if the motor voltage is higher than the value set here. During the run, the voltage may fall to 17.5 V.	180... 240 16 bit	Yes	185	R/W
UMot filter	203D	Average time for motor voltage measurement;  value in ms	100... 1000 16 bit	Yes	100	R/W
Temp. limit	203E	Upper temperature limit in °C	10...80 16 bit	Yes	80	R/W
Device temperature	203F	Internal device temperature in °C	16 bit			R
Production date	2040	Year and week of manufacture (given as an integer)	YYWW 16 bit			R
Serial number	2041	Device serial number	0... 65535 16 bit			R
Max. holding torque at end of run	2042	Value in cNm	See chap. 3.4  16 bit	Yes	See chap. 3.4	R/W
Duration of max. holding torque at end of run	2043	Time period during which the holding torque is applied at completion of run;  value in ms	0...1000 16 bit	Yes	200	R/W
Waiting time for brakes	2045	Reserved				
Drag error correction	2046	Reserved				
Readjustment	2047	Adjustment when at a standstill 0 → off; 1 → on	0...1 8 bit	Yes	0	R/W
Configuration for connection failure	2049	Reserved				

Designation	Index no.	Function	Range of values	Back-up?	De-livery state	R/W
Safe position for connection failure	204A	Reserved				
Repeat time for safety run	204B	Reserved				
Device type	204D	Device type within the PSD range as a string (e.g. "PSD403-18-H")				R
Version	204E	Software version number	16 bit			R
Delivery state	204F	<p>Writing a "-6": Resets the drive (corresponds to switching the control voltage off and back on)</p> <p>Writing a "-5": Sets the values of all parameters to the delivery state, saves the parameters in EEPROM, then positions the drive in the middle of the measurement range *) (Station name and IP address are not affected)</p> <p>Writing a "-4": Sets the values of all parameters to the last values saved by the user, then positions the drive in the middle of the measurement range *) (Station name and IP address are not affected)</p> <p>Writing a "-3": Sets the values of all parameters to the delivery state, deletes the station name and IP address and saves the parameters in EEPROM</p> <p>Writing a "-2": Sets the values of all parameters to the last values saved by the user, without saving the parameters in EEPROM (Station name and IP address are not affected)</p> <p><i>Continues on next page</i></p>	-6 ... -1 or 1  (during writing)  ±15 bit	No		R/W

Designation	Index no.	Function	Range of values	Back-up?	De-livery state	R/W
Delivery state	204F	<p>Writing a “-1”: Sets the values of all parameters to the delivery state, without saving the parameters in EEPROM (Station name and IP address remain unaffected)</p> <p>Writing a “1”: Saves the parameters in EEPROM</p> <p>Writing only possible when at a standstill.</p>	<p>-6 ... -1 or 1</p> <p>(during writing)</p> <p>±15 bit</p>	No		R/W

\*) The positioning run to the middle of the measurement range can be aborted at any time by setting control word = 0 with SDO #2024 (if state is not "operational") or via the PDO control word. Furthermore, in "operational" state, the PDO control word is ignored during the positioning run to the middle of the measurement range (unless it changes). Thus, a run to the middle of the range can also be aborted by changing the PDO control word. Run commands issued before the positioning run to the middle of the range will not be automatically resumed after this run has been completed, (i.e. the PDO control word 0x14 and the old target value do not result in the drive moving to this position).

### 3.4 Table of device-dependent min., max. and default values

#### NOTICE

The operating torque setting is optimised for the nominal rated speed of the respective device model. The more the set speed deviates from the nominal rated speed (rpm), the greater the actual difference between the actual power consumption of the motor circuit and the set value.

#### NOTICE

Setting the value for the max. holding torque to 0 results in a maximum current consumption by the motor circuit of approx. 50 mA

Device type		PSD 401/411 - 5V	PSD 401/411 - 8H/14H	PSD 403/413 - 8H/14H	PSD 422/432 - 8V	PSD 422/432 - 8H/14H
Name	Index no.	Range of values Delivery state				
Upper mapping end *)	2028	806,400	806,400	198,498	806,400	806,400
Upper limit *)	2016	805,200	805,200	197,298	805,200	805,200
Lower limit *)	2017	-805,200	-805,200	-197,299	-805,200	-805,200
Target speed for positioning run	2012	1...800 200	1...500 200	1...250 50	1...1000 200	1...500 200
Target speed, manual run	2013	1...800 70	1...500 70	1...250 17	1...1000 70	1...500 70
Acceleration	201C	1...5000 1000	1...5000 1000	1...1250 250	1...5000 500	1...5000 500
Deceleration	201D	1...5000 2000	1...5000 2000	1...1250 500	1...5000 2000	1...5000 2000
Maximum start-up torque	2018	30...90 50	30...90 50	115...350 190	50...240 120	50...240 120
Maximum torque	2014	30...80 40	30...80 40	115...300 150	50...240 100	50...240 100

Maximum holding torque at end of run	2042	0...80 30	0...80 30	0...325 120	0...200 70	0...200 70
Maximum holding torque	202B	0...60 20	0...60 20	0...245 80	0...150 50	0...150 50

Device type		PSD 424/434 - 14H	PSD 426/436 - 14H	PSD 428/438 - 14H	PSD 480/490 - 5V	PSD 480/490 - 8H/14H	PSD 481/491 - 8H/14H
Name	Index no.	Range of values Delivery state					
Upper mapping end *)	2028	388,800	256,000	196,683	806.400	806.400	198.498
Upper limit *)	2016	387,600	254,800	195,483	805.200	805.200	197.298
Lower limit *)	2017	-387,600	-254,800	-195,483	-805.200	-805.200	-197.298
Target speed for positioning run	2012	1...482 100	1...317 63	1...250 50	1...800 200	1...500 200	1...250 50
Target speed, manual run	2013	1...482 34	1...317 22	1...250 17	1...800 70	1...500 70	1...250 17
Acceleration	201C	1...2411 240	1...1587 150	1...1250 125	1...5000 1000	1...5000 1000	1...1250 250
Deceleration	201D	1...2411 960	1...1587 635	1...1250 500	1...5000 2000	1...5000 2000	1...1250 500
Maximum start-up torque	2018	100...480 240	150...720 360	195...935 465	9...30 15	9...30 15	26...120 60
Maximum torque	2014	100...480 200	150...720 300	200...935 400	9...30 13	9...30 13	36...120 50
Maximum holding torque at end of run	2042	0...400 140	0...630 220	0...820 285	0...25 9	0...25 9	0...100 35
Maximum holding torque	202B	0...300 100	0...470 155	0...615 205	0...19 7	0...19 7	0...75 25

\*) The min. and max. values for the parameters cannot be specified because they are dependent on the current scaling. The value is valid for the standard scaling (400 increments per rotation).

### 3.5 Process data format

#### 3.5.1 Output module (from the perspective of the IO controller)

Bit	Byte	Meaning	Corresponding SDO index number
0-15	0.1	Status word	2025h
16-31	2-3	Current rpm	2030h
32-63	4-7	Actual value	2003h

#### NOTICE

Assignment (cannot be modified)

#### 3.5.2 Input module (from the perspective of the IO controller)

Bit	Byte	Meaning	Corresponding SDO index number
0-15	0.1	Control word	2024h
16-47	2-5	Target value	2001h

#### NOTICE

Assignment (cannot be modified)

### 3.6 Detailed description of status bits

#### Bit 0 Target position reached

*This bit is set:*

- when a transferred target position has been reached successfully (not at the end of a manual run, except when the target position is also the specified limit)
- as a result of manual displacement during standstill, if the actual position of the drive is once again within the positioning window
- after manual displacement while at standstill, if readjustment is activated and the absolute value of the difference of actual and target value is smaller or equal to the positioning window again.

**If bit 0 is set at the same time as bit 10 (obstruction), bit 0 has priority!**

*This bit is reset:*

- after transferring a target position when the difference from the actual value is larger than the positioning window (SDO #2006)
- by a manual run
- if an invalid target value has been transferred
- as a result of manual displacement during standstill

#### Bit 1 Reserved

#### Bit 2 Toggle Bit

*This bit is set:*

- when bit 13 of the control word is set

*This bit is reset:*

- when bit 13 of the control word is deleted

#### Bit 3 Reserved

#### Bit 4 Power supply to motor available

*This bit is set:*

- if the supply voltage for the motor is above the UMot limit (SDO #203C) and below 30 V

*This bit is reset:*

- if the supply voltage for the motor is below the UMot limit or above 30 V



**Bit 5 Positioning run aborted**

*This bit is set:*

- If a positioning run is aborted because the release has been withdrawn in the control word or due to an invalid bit combination in the control word

*This bit is reset:*

- For every new run command

**Bit 6 Drive is running**

*This bit is set:*

- when the drive is rotating

*This bit is reset:*

- when the drive is at a standstill

**Bit 7 Temperature too high**

*This bit is set:*

- when the internal device temperature exceeds the limit specified in SDO #203E

*This bit is reset:*

- when the internal device temperature falls below the limit value by 5 °C

**Bit 8 Run in opposite direction to loop**

*This bit is set:*

- after power up or a reset (a lash in a driven spindle which might be present has not yet been eliminated)
- when initiating a positioning run or manual run in the opposite direction to the reference loop

*This bit is reset:*

- when SDO #201F=0 and a positioning run or manual run is initiated
- when a transferred target position has been reached successfully in the direction of the reference loop (not after a manual run)

**Bit 9 Error bit**

*This bit is set:*

- when an internal problem is detected when calculating the position  
No run commands may be transmitted when the error bit is set!

*This bit is reset:*

- only possible by resetting the drive

**Bit 10 Positioning error (obstruction)**

*This bit is set:*

- if a positioning run or manual run is aborted because the device is overloaded (obstructions, extreme difficulty running)

**If bit 0 (target position reached) is set at the same time as bit 10 (obstruction), bit 0 has priority!**

*This bit is reset:*

- for every new run command

**Bit 11 Manual rotation**

*This bit is set:*

- if, while at a standstill, the drive is turned by an external force by more than the value in the positioning window, after a positioning run has been finished successfully

*This bit is reset:*

- for every new run command

**Bit 12 Incorrect target value**

*This bit is set:*

- if a transferred target value lies outside the range limits, caused e.g. by the current reference value (SDO #2004)
- if a transferred target value lies within the range limits, but would leave the specified range during the required reference loop

*This bit is reset:*

- for every new run command

**Bit 13 Motor voltage was missing**

*This bit is set:*

- if the motor voltage is less than the UMot limit (SDO #203C) or above 30 V when initiating a positioning run or manual run
- if the motor voltage leaves the specified range during the run

*This bit is reset:*

- if the motor voltage is greater than the UMot limit and under 30 V when initiating a positioning run or manual run

**Bit 14/** **Forward/reverse limit reached**

**Bit 15**

*This bit is set:*

- if the limit value is reached during a manual run (not when reached during a positioning run)
- if an end limit is modified such that the current position lies beyond it
- if, when at a standstill, the drive is moved to a position beyond the range limits by an external force

*This bit is reset:*

- as soon as the drive is once again within the range limits (exception: after the end of a manual run, the drive is still at the range limit within the positioning window and no new run command has yet been issued.)

### 3.7 Detailed description of control bits

**Bit 0**      **Manual run to larger values**

**Bit 1**      **Manual run to smaller values**

**Bit 2**      **Transfer target value**

When this bit is set, the target value in the process data is accepted as the new valid target value. A positioning run starting at the same time or later will use this target value as the new target position. If the positioning run is required to start as soon as the the target value has been transferred, bit 4 ("release") must also be set.

If bit 2 is not set, the target value will not be accepted. Instead, a positioning run can be started to the last transmitted target value that has been marked as valid.

**Bit 3**      **Reserved**

must be set to 0

**Bit 4**      **Release**

Run commands will only be executed if this bit is set. This bit must be set for positioning runs and manual runs. If this bit is deleted during a run, the run will be aborted and status bit 5 ("Positioning run aborted") will be set.

**Bit 5**      **Reserved**

must be set to 0

**Bit 6**      **Run without a reference loop**

If this bit is set, all target positions will be approached directly during positioning runs (independently of the current value of SDO #201F), without a reference loop.

**Bit 7-12**   **Reserved**

must be set to 0

**Bit 13:**   **Toggle bit**

The drive always writes this bit in status word bit 2.

→ The control unit can recognise when new process data from the drive are processed.

**Bit 14-15:** **Reserved**

must be set to 0

## 4 Functions

### 4.1 Positioning

The drive must be switched to the ESM status “operational” before it can be controlled using PDOs.

- Transfer target value:  
PDO with control word = 0x14 and desired target value  
→ drive begins to run
- Aborting a run by withdrawing release:  
PDO with control word = 0x00

If a new target value is transferred during a positioning run, the device will immediately proceed to the new target. This will occur with no interruption provided the direction of rotation does not need to be altered.

If a manual run command is transmitted during a positioning run, the positioning run will be aborted (velocity will be reduced to that of a slow run) and the operator may proceed with the manual run.

**The following sequence of steps is also possible:**

Starting conditions: release has not been set.

- Transfer target value:  
PDO with control word = 0x04 and desired target value
- Set release:  
PDO with control word = 0x10  
→ drive begins run

#### NOTICE

Positioning runs may include a “reference loop”, which ensures the target is approached from a defined direction. The direction and length of the reference loop can be set to the required value before the positioning run using SDO #201F (“length of loop”). SDO #201F can also be used to deactivate the reference loop.

#### NOTICE

The control word and target value can only be transmitted using SDOs in the ESM status “pre-operational”.

## 4.2 Types of positioning

### 4.2.1 Positioning run *with* reference loop

The PSD4xx distinguishes between the following steps of a positioning sequence (Assumption: the target position is always approached through forward motion)

- 1) New position value is larger than the current value:  
position approached directly.

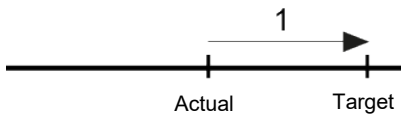

- 2) New position value is smaller than the current value:  
the drive reverses an additional 5/8 of one rotation (2a)  
and approaches the exact position after resuming forward motion (2b).

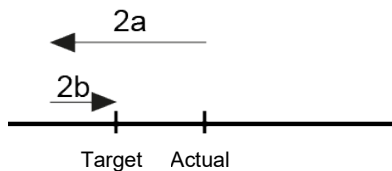

- 3) New position value after reverse run (no reference loop):  
the drive always approaches by moving forward (3b),  
if necessary, it will first reverse by 5/8 of a rotation (3a).

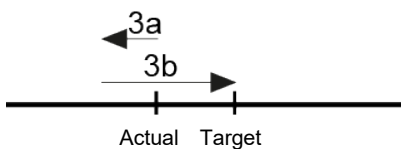

After reaching the target position, this position is compared with the internal absolute encoder position. When positioning outside the positioning window (SDO #2006) a second positioning is automatically started and the drive will move to the target position again. If there is another deviation outside the positioning window, the status bit "Positioning error (blocking)" is set.

### NOTICE

It is not possible to perform a positioning run to the upper limit (SDO #2016) with a length of loop > 0 because the drive would have to run past the upper limit in order to do so. The same applies to the lower limit (SDO #2017) with a length of loop < 0.

#### 4.2.2 Positioning run *without* reference loop

The “positioning without a reference loop” mode is used primarily for moving the small distances involved in fine adjustments. In this case, each position is approached directly.

#### NOTICE

This does NOT eliminate any lash present in the driven spindle.



#### CAUTION!

Runs, which intentionally involve a run to an obstruction (e.g. reference runs to a block), may only be started with reduced torque (running torque to minimum value).

#### 4.2.3 Manual run

The drive can be operated manually (so called “Manual run”). This helps to simplify start-up.

##### Start manual run:

- Transfer control word  
PDO with control word = 0x11 and/or 0x12  
→ Starts the manual run

##### End manual run:

- Transfer control word or reset release bit  
PDO with control word = 0x10 and/or 0x00  
→ Stops the manual run

#### NOTICE

If a positioning run is required during an active manual run, the drive must be stopped (reset the release bit). The positioning run can be initiated as soon as the drive is stationary (PDO with control word = 0x14 and the desired target value).

If pre-operational, set target value to SDO #2001. The drive then automatically deletes the manual run bits from the control word (bits 0 and 1).

Manual runs are executed using the maximum max. velocity from SDO #2013, positioning runs using the maximum velocity from SDO #2012.

For all runs, the maximum acceleration from SDO #201C and the maximum deceleration from SDO #201D apply.

As the drive approaches the target at the end of the run, the maximum deceleration is successively reduced in order to ensure a harmonious transient response.

If a stop command is executed, the drive brakes with the maximum possible deceleration ramp independently of the value in SDO #201D.

### 4.3 Maximum start-up and operating torque

The maximum start-up torque can be set using SDO #2018, the maximum operating torque using SDO #2014.

The start-up torque is active after each run begins for the period defined in SDO #2019.

#### NOTICE

The stepper motor is optimized for maximum torque. If the PSD is operated at speeds above 400 rpm, self-resonance or even self-locking occurs. Just by adding an inert mass, the natural resonance is significantly damped!

#### NOTICE

The start-up torque should always be slightly higher than the operating torque because the drive requires more power during the acceleration phase compared to a state of constant velocity

#### NOTICE

If small torque limits are to be used, the following must be considered: Small operating torque values should not be used in combination with high speed settings as this can lead to instability!



#### 4.4 How to respond if the drive encounters an obstruction

If an obstruction is detected, the run is aborted and the "Positioning error" bit is set. The PSD4xx now operates with the specified maximum holding torque (SDO #2042).

After this, new run commands can be sent without taking further measures, i.e. transferring a new target position (changing the value of the target position in the process data) starts a new positioning run.

**Exception:**

The exception to this is if the target value is the same as before. In this case, cancel the release and reset it (bit 4 in the control word). Bit 2 ("Transfer target value") must be set in this case. The drive then begins a new positioning run.



#### CAUTION!

Runs which intentionally involve a run to an obstruction (e.g. reference runs to a block) may only be started with a reduced torque (max. operating torque < 10 % of nominal rated current or smallest possible value).

#### 4.5 How to respond if drive is turned manually (adjustment function)

If the PSD4xx is rotated in the opposite direction from the reference loop – when at a standstill, after a correctly completed positioning run and the release bit (bit 4 in the control word) as well as the readjustment bit (SDO #2047) are activated – it will again attempt to run to the previously sent target value (adjustment). After successful readjustment bit 0 will be set again.

The device does not attempt to adjust if rotated in the direction of the reference loop, it will merely set bit 11 of the status word (“Manual rotation”) and reset bit 0 (“Target position reached”). If the reference loop is deactivated (SDO #201F = 0), the drive will adjust in both directions.

#### NOTICE

The device does not attempt to adjust if rotated in the direction of the reference loop, it will merely set bit 11 of the status word (“Manual rotation”) and reset bit 0 (“Target position reached”).

#### NOTICE

If the drive continually loses its position when at a standstill, it will attempt to adjust whenever its actual position just leaves the positioning window (provided that all of the above-mentioned conditions are met). At this time, the motor voltage must be within the permissible range (i.e. bit 4 is set in the status word).

No adjustment will start if the motor voltage is not in the permissible range. Instead, bits 10 (“Positioning error”) and 13 (“Power was unavailable to motor”) will be activated.

If the motor voltage only returns to the permissible range after leaving the positioning window, no new adjustment attempt will start. This prevents a situation in which the drive suddenly starts to move when the motor voltage is switched on.

If a positioning run or manual run is aborted while in progress by a stop command (“Release” bit in control word to 0), the drive will only adjust when a new run command is sent and completed correctly.

Deleting the release bit and/or adjustment function can completely prevent the adjustment process.

#### 4.6 Calculate the absolute physical position

The PSD4xx actuator includes an absolute measuring system capable of covering a range of 4,026 rotations. This allows the user to determine the direction of rotation for any desired portion of these 4,026 rotations.

The mapping of the desired positioning range to the physical positioning range “mapping end” is performed via SDO #2028.

In the delivery state, the drive is positioned at 0, the upper limit is 805,200, the lower limit is - 805,200. This results in a positioning range of  $\pm 2,013$  rotations ( $\pm 805,200$  steps). If the desired positioning range does not exceed  $\pm 2,013$  rotations, none of the steps described below are required to set the positioning range in the delivery state.

The following two options are available to allow you to realise any desired positioning run distances independently of the run distance set by the mounting orientation of the measurement system (physical positioning range):

- 1) Bring the axle to be moved (e.g. a spindle) into the desired position, run the drive to the appropriate position with the adjustable collar open and only then close the adjustable collar.

##### Examples:

- a) Bring the axle to be positioned into the mid-position, run the drive in neutral (with the adjustable collar open) to the mid-position (position 0), then close the adjustable collar. The drive can now run 2,013 rotations in both directions (default  $\pm 805,200$  increments).
  - b) Bring the axle to be positioned all the way to the left (or bottom), run the drive in neutral (with the adjustable collar open) without a loop to the smallest position (position - 805,200), then close the adjustable collar. The drive can now run 4,026 rotations to the right (or top) (default 1,610,400 increments).
  - c) Bring the axle to be positioned all the way to the right (or top), run the drive in neutral (with the adjustable collar open) to the largest position (position 805,200), then close the adjustable collar. The drive can now run 4,026 rotations to the left (or bottom) (default 1,610,400 increments).
- 2) Mount the drive in the required position on the axle, close the adjustable collar, then adjust the positioning range using SDO #2028. SDO #2028 sets the upper end of the positioning range. Default setting: upper end at +2,016 rotations (position 806,400). If, after mounting the drive, the positioning range does not match the currently displayed position, you can select the positioning range between + 3 ... +4029 rotations.

**Examples:**

- a) After mounting the drive, the position 0 is displayed (which corresponds to the delivery state). The positioning range should point exclusively to the right (or top)
  - Upper mapping end = Position +4,029 rotations
  - Set SDO #2028 to 1,611,600.
- b) After assembly, the displayed position is 804,000. However, the positioning range should point exclusively to the right (or top)
  - Upper mapping end = Position +4,029 rotations
  - Set SDO #2028 to 2,415,600.
- c) After assembly, the displayed position is -804,400. However, the positioning range should point exclusively to the left (or bottom)
  - Upper mapping end = Position +3 rotations
  - Set SDO #2028 to -803,200.

**Notes:**

- 1) When calculating the upper mapping end (SDO #2028) (as in the above examples), it is essential to include a safety margin of 3 rotations (by default 1,200 increments), because the highest possible position value is 3 rotations below the upper mapping end. The smallest possible position value is 4,029 rotations below the upper mapping end.
- 2) The numbers of increments or position values indicated relate to the following settings, which correspond to the delivery state:
  - a) Reference value (SDO #2004) = 0
  - b) Position scaling, numerator (SDO #2010) = 400
  - c) Position scaling, denominator (SDO #2011) = 400

These 3 parameters affect the above numbers of increments or position values: The reference value can be used to shift the range of values, the numerator/denominator to stretch or extend the range of values (see below).

- 3) If the direction of rotation is changed (SDO #202C), the reference value (SDO #2004), the upper mapping end (SDO #2028) and the upper and lower limits (SDO #2016 and #2017) will be reset to the delivery states.
- 4) When the upper mapping end is changed (SDO #2028), the upper and lower limits (SDO #2016) will be reset to the delivery states.
- 5) If the positioning scaling is changed (numerator: SDO #2010 or denominator: SDO #2011), the target value, actual value, reference value, upper mapping end and the upper and lower limits, positioning window and length of loop will be recalculated.
- 6) If the reference value is changed (SDO #2004), the target value, actual value, upper mapping end and the upper and lower limits will be recalculated.

- 7) If the user wants to avoid any automatic adjustment of values when setting the parameters for the drive, the optimum order for sending the parameters is as follows:
- a) Direction of rotation (SDO #202C)  
Positioning scaling, numerator (SDO #2010)  
Positioning scaling, denominator (SDO #2011)
  - b) Reference value (SDO #2004)
  - c) Upper mapping end (SDO #2028)
  - d) Positioning window (SDO #2006)  
Length of loop (SDO #201F)
- 8) To save the settings permanently in EEPROM write a 1 in SDO #204F.  
Saving can take up to 1 second.

**Reference value (SDO #2004):**

The referencing process affects all transferred values, i.e., the target value, actual value, upper mapping end and upper and lower limits.

There are two ways of setting the referencing value:

- 1) Directly – by writing the referencing value in SDO #2004.
- 2) Indirectly – by writing an actual value to SDO #2003. This makes it possible to assign any “true” actual value to the current, physical actual value. The resulting difference is then the referencing value. This value will immediately be included in calculations for each transferred value and can also be read under SDO #2004.

If the reference value is changed, the target value, actual value, upper mapping end and the upper and lower limits will be recalculated.

**NOTICE**

Removal of the supply voltage to the **motor** has no effect on the internal measurement system.

#### 4.7 Set the spindle pitch

Using SDO #2010 (numerator factor) and SDO #2011 (denominator factor), it is possible to represent any desired spindle pitch using positioning scaling factors:

$$\text{Number of increments per rotation} = 400 \times \frac{\text{Denominator factor}}{\text{Numerator factor}}$$

Both factors are set to a value of 400 by default, resulting in a resolution of 0.01 mm at a spindle pitch of 4 mm.

The denominator factor serves as a simple means of setting the spindle pitch and resolution. The numerator factor is primarily used for setting "uneven" resolutions.

#### Examples:

Spindle pitch	Resolution	Numerator factor	Denominator factor
4 mm	1/100 mm	400	400
1 mm	1/100 mm	400	100
2 mm	1/10 mm	400	20

#### NOTICE

Numerator and denominator factors may take on values between 1 and 10,000

#### 4.8 Abort the run when the master fails

If the connection to the EtherCAT master is interrupted during a positioning run, the master cannot abort a run that is already underway. The connection between master and slave is monitored using a Sync Manager Watchdog so that an automatic run abort can be generated in such a case. If there is no valid process data exchange within the specified time (default value = 100 ms), a connection failure will be diagnosed. The drive will abort the run and not start a new positioning run until the connection to the EtherCAT master has been re-established.

## 4.9 Reference runs

The PSD4xx positioning system is equipped with an absolute measuring system, so no reference run is required when the drive is switched on. If a reference run should be required to a hard obstruction in a specific instance (e.g. once during installation of the drive on a machine), the procedure should be as follows:

- 1) Prior to ordering the reference run, adjust the settings as follows:
  - a) Set max. operating torque (SDO #2014) and max. start-up torque (SDO #2018) to 10 % of the max. value, resp. the lowest possible values.
  - b) Set max. holding torque (SDO #202B) and max. holding torque at the end of the run (SDO #2042) to 0.
  - c) Set the speed limit (rpm) for aborting run (SDO #201A) to 60.
  - d) Set the time elapsed until falls below speed limit for aborting run (SDO #201B) to 100. (The time during which the drive tries to overcome the obstruction decreases: with these reduced values, the positioning run is aborted if the speed (rpm) remains below 60 % of the target speed for longer than 100 ms. The default settings are 200 ms and 30 %.)
  - e) Set the affected end limit (SDO #2016 or SDO #2017) so that the obstruction is clearly within the limit in each case. (Otherwise there is a risk that the obstruction will lie within the positioning window and therefore not be recognised.)
  - f) If necessary, reduce the target speed for manual operation (SDO #2013)
- 2) Now start the reference run as a manual run (bit 0 or 1 in the control word).
- 3) Wait until the drive is running (bit 6 is set in the status word)
- 4) Wait until the drive is stationary and a positioning error has occurred (bit 6 of the status word is reset, bit 10 is set).
- 5) Using the same settings, perform a manual run in the opposite direction (move a little distance away from the obstruction so the drive can move freely).
- 6) Only now use desired settings for normal operation of the above SDOs.

#### 4.10 Run drive in reverse

Depending on the model, the drive may be run in reverse up to a certain speed.



### CAUTION!

Running a PSD4xx in reverse for more than 1-2 seconds at more than the permissible speed will damage the internal protection diode and the PSD4xx will be defective.

Please refer to the following table to find the maximum permissible speed:

Device model	PSD 401/411 - 5V/8H/14H	PSD 403/413 - 8H/14H	PSD 422/432 - 8V/8H/14H	PSD 424/434 - 14H	PSD 426/436 - 14H
Max. permissible speed [rpm]	200	48	200	95	60

Device model	PSD 428/438 - 14H	PSD 480/490 - 5V	PSD 480/490 - 8H/14H	PSD 481/491 - 8H/14H
Max. permissible speed [rpm]	45	200	200	48



## 5 Technical data

Technical data and drawings can be found in the current data sheet on the website:  
[www.halstrup-walcher.de/technicaldocu](http://www.halstrup-walcher.de/technicaldocu)

Please search for "PSD" and select your type, click on "Data sheets".

Please contact us if you require any further information.

## 6 Notes





